



Global Energy Partners, LLC
AN EPRI, DMJMHN COMPANY



Electricity Innovation Institute

EPRI

Final Summary Report

Project Definition Study

Offshore Wave Power Feasibility Demonstration Project

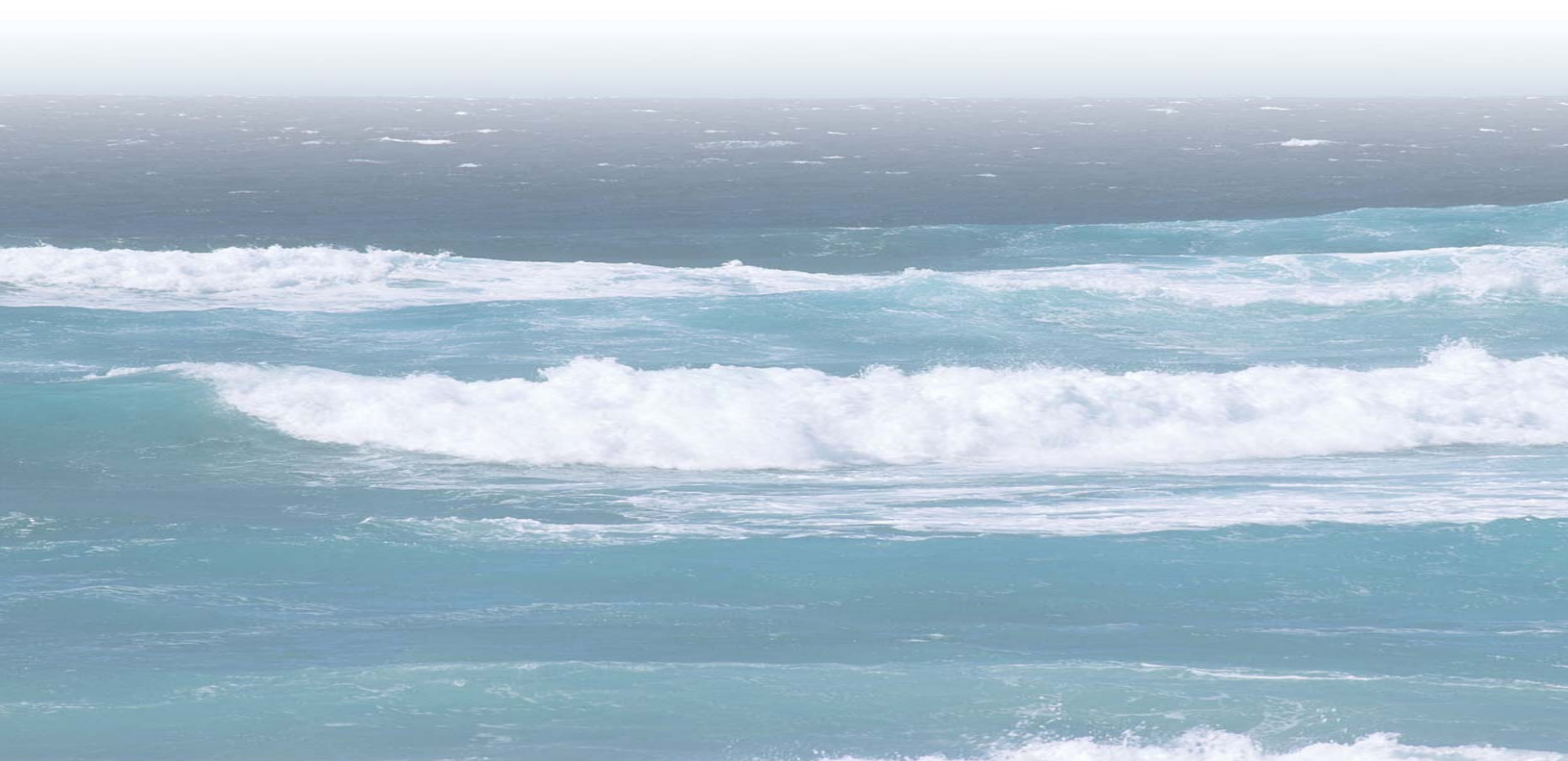

Report: E2I EPRI Global WP 009 - US
Author: Roger Bedard
Coauthors: George Hagerman, Mirko Previsic, Omar Siddiqui, Robert Thresher, Bonnie Ram
Date: January 13, 2005

DISCLAIMER OF WARRANTIES AND LIMITATION OF LIABILITIES

This document was prepared by the organizations named below as an account of work sponsored or cosponsored by the Electric Power Research Institute Inc. (EPRI). Neither EPRI, any member of EPRI, any cosponsor, the organization (s) below, nor any person acting on behalf of any of them:

(A) Makes any warranty or representation whatsoever, express or implied, (I) with respect to the use of any information, apparatus, method, process or similar item disclosed in this document, including merchantability and fitness for a particular purpose, or (II) that such use does not infringe on or interfere with privately owned rights, including any parties intellectual property, or (III) that this document is suitable to any particular user's circumstance; or

(B) Assumes responsibility for any damages or other liability whatsoever (including any consequential damages, even if EPRI or any EPRI representative has been advised of the possibility of such damages) resulting for your selection or use of this document or any other information, apparatus, method, process or similar item disclosed in this document.

Organization(s) that prepared this document

Electricity Innovation Institute

Global Energy Partners LLC

Virginia Polytechnic Institute and State University

Mirko Previsic Consulting

DOE National Renewable Energy Laboratory

Energetics

Acknowledgements

The first phase of the Offshore Wave Power Feasibility Project was the product of many organizations and individuals. The EPRI Global Project Team gratefully acknowledges those contributions and extends its gratitude to both those listed here as well as the countless others who are not specifically listed by name.

First, the EPRI Project Team consisted of the following individuals:

- Roger Bedard – EPRI – Project Management and Client Liaison
- George Hagerman – Virginia Tech – Oceanography, Wave Resource, Site Characterization and Environmental Issues
- Mirko Previsic – Private Consultant – Wave Energy Conversion Device Assessment, Plant System Design, Performance and Cost
- Omar Siddiqui – Global Energy Partners LLC (a subsidiary of EPRI) – Economic Assessment
- Robert Thresher – National Renewable Energy Laboratory (NREL) – Permitting Issues
- Bonnie Ram – Energetics – Permitting Issues

For their sponsorship, invaluable help in guiding the project definition study and networking with local stakeholders, we thank the following people:

- Jim Atwell and Janet Yancey-Wrona – Maine Technology Institute
- Rob Pratt and David McCarron – Massachusetts Technology Collaborative
- Dwayne Breger and Rob Sydney – Massachusetts Department of Energy Resources
- Bill Peden and Ed Smeloff of the San Francisco Public Utility Commission
- Scott Wentworth of the City of Oakland
- Peter O'Donnell and Jared Blumenfeld of the San Francisco Department of the Environment
- Kevin O'Sullivan, Mike Hoffman, Terry Oliver and Anne Morrow of Bonneville Power Agency
- Chris Fate and Barbara Beck of Snohomish Public Utility District
- Art Seki and Darren Ishimura of the Hawaiian Electric Company

For their provision of in-kind regulatory and permitting issues research services contribution in the form of Dr. Robert Thresher of the DOE NREL and Ms. Bonnie Ram and her staff at Energetics, we thank the U.S. Department of Energy.

This project would not have been possible without the information provided by wave energy conversion device manufacturers. For their openness and willingness to answer our myriad of questions, we would like to extend our sincere appreciation to:

- AquaEnergy
- Energetech
- Independent Natural Resources
- Ocean Power Delivery
- OreCON Ltd
- Teamwork Tech
- WaveBob Ltd
- Wave Dragon ApS

As offshore wave power plants must connect with the grid, interconnection data was needed in order to characterize sites and design systems. We would like to thank the following transmission and distribution utilities for providing grid interconnection information to us during this project:

- Bangor Hydro
- Central Maine Power
- Pacific Gas and Electric
- Bonneville Power Agency
- Central Lincoln PUD
- Hawaiian Electric Company
- Kauai Island Electric Cooperative

We also thank Sea Engineering Hawaii for information on installation of mooring, devices and power cables.

If, despite our best efforts, errors survive in the pages of this summary report or in our referenced technical reports, the fault rests entirely with the EPRI E2I Global Project Team. And if I inadvertently omitted the names of any persons or organizations that should have been acknowledged, I offer my sincere apologies.

Roger Bedard

PS.

In order to understand the principles by which wave energy conversion devices work and to estimate the power of waves, it is necessary to understand the fundamentals of wave motion. It is not the purpose of this report to provide that understanding. There are many good books and websites by which that understanding can be obtained. A glossary is provided at the back of this report to help the uninitiated reader understand some of the wave energy specialty vocabulary

Table of Contents

1. Introduction and Summary	6
2. Wave Energy and the Rationale for this Project	9
3. Project Approach	10
4. Methodology Development	11
5. Site Identification and Characterization	12
6. Wave Energy Conversion Device Assessment	13
7. Power Plant Design, Performance, Cost and Economic Assessment	15
8. Environmental Issues	24
9. Permitting Issues	27
10. Conclusions	28
11. Recommendations	29
12. References	31
13. Glossary	32

1. Introduction and Summary

This document summarizes the results of a study performed by an E2I EPRI Global Project Team (herein referred to as the Project Team) to define offshore wave energy feasibility demonstration projects within the territorial waters of the United States. The techno-economic rationale for investing in offshore wave energy technology is a function of the commercial viability of the technology to convert wave energy into electricity. The outcome of this study is a compelling case for investing in wave energy related research, development and demonstration (RD&D) including the feasibility demonstration of one or more offshore wave power plant projects. The elements of this project definition study were:

- Identify and characterize potential sites,
- Identify and assess wave energy conversion (WEC) devices,
- Design a demonstration- and commercial-scale offshore wave power plant and, based on performance and cost estimates, assess the techno-economic viability of the wave energy source and the energy conversion technology,
- Identify and assess the environmental and regulatory issues associated with implementing the technology.

Sites or locations for assembling, launching and deploying the power plant, for connecting the plant to the electrical grid and for operating and maintaining the plant were identified and characterized. Technical Reports (References 3 through 6) describe the results of site identification and characterization in the States of Hawaii, Washington, Oregon and Maine.

The sites chosen for five point design studies performed in this project are:

<u>State</u>	<u>County</u>	<u>Harbor</u>	<u>Grid Interconnection</u>
CA	San Francisco	San Francisco	Ocean Beach Water Treatment Plant
HI	Oahu	Honolulu	Makai Pier, Waimanalo Beach
ME	Cumberland	Portland	Old Orchard Beach Substation
MA	Boston	Boston	Wellfleet distribution line
OR	Douglas County	Coos Bay	Gardiner Substation

The wave energy resource in each of these states is most commonly described in terms of average annual power flux (kW/m of wave crest length). The average annual power flux of the selected sites in the above five states and Washington State are:

	SF CA	HI	ME	MA	OR	WA
Average Annual Power Flux at Selected Site (kW/m)	20.0	15.2	4.9	13.8	21.2	26.5

WEC device information was obtained from twelve worldwide device manufacturers. The Project Team assessed these WEC devices based on maturity of development, technical issues and cost projections. A Technical Report (Reference 7) describes the results of the WEC device assessment. At the time of this assessment (March 2004) only one WEC device manufacturer had attained a feasibility demonstration technology readiness status, namely, Ocean Power Delivery with its Pelamis device. At this time (January 2005), there are an additional four WEC device manufacturers that are close to reaching that status, namely: TeamWorks of the Netherlands with its WaveSwing, Energetechs of Australia with its oscillating water column, WaveDragon of Denmark with its overtopping device and Ocean Power Technology of the U.S. with a floating buoy.

Offshore wave energy is an emerging technology. One sign or indicator of this technology immaturity is the lack of industry standard methodologies. Technical Reports describe the methodologies that were developed and used by the Project Team to design the offshore wave power plant, estimate the annual power production, and estimate the cost of the plant and the cost of electricity (References 5, 2 and 1, respectively).

The techno-economic forecast made by the Project Team is that wave energy will first become commercially competitive with the current 40,000 MW installed land-based wind technology at a cumulative production volume of 15,000 or less MW in Hawaii and northern California, about 20,000 MW in Oregon and about 40,000 MW in Massachusetts. This forecast was made on the basis of a 300,000 MWh/yr (nominal 90 MW at 38% capacity factor) Pelamis WEC commercial plant design and application of technology learning curves. Maine was the only state in our study whose wave climate was such that wave energy may never be able to economically compete with a good wind energy site.

In addition to economics, there are other compelling arguments for investing in offshore wave energy technology. First, with proper siting, converting ocean wave energy to electricity is believed to be one of the most environmentally benign ways to generate electricity. Second, offshore wave energy offers a way to minimize the 'Not In My Backyard' (NIMBY) issues that plague many energy infrastructure projects, from nuclear to coal and to wind generation. Because these devices have a very low profile and are located at a distance from the shore, they are generally not visible. Third, because wave energy is more predictable than solar and wind energy, it offers a better possibility than either solar or wind of being dispatchable and earning a capacity payment.

A characteristic of wave energy that suggests that it may be one of the lowest cost renewable energy sources is its high power density. Processes in the ocean concentrate solar and wind energy into ocean waves making it easier and cheaper to harvest. Solar and wind energy sources are much more diffuse, by comparison.

Lastly, since a diversity of energy sources is the bedrock of a robust electricity system, to overlook wave energy is inconsistent with our national needs and goals. Wave energy is an energy source that is too important to overlook.

This summary report is organized into the following sections

- Section 2 – Describes wave, wave energy and the rationale for this project
- Section 3 – Describes the approach used to perform the project definition study
- Section 4 – Describes the technical methodology used to design the wave plants and estimate their performance and cost
- Section 5 – Describes the coastline that was surveyed for identifying and characterizing wave power plant sites
- Section 6 – Describes the assessment of the technological readiness of wave energy conversion devices
- Section 7. – Describes the results of the demonstration and commercial-scale designs and the predicted performance, cost and economics
- Section 8 – Describes the identification of environmental related issues
- Section 9 – Describes the current regulatory uncertainty and the issues that must be satisfied to permit a plant
- Section 10 – Describes the Project Team’s primary conclusions formed from this study
- Section 11 – Describes the Project Team’s primary recommendations as a result of this study
- Section 12 – Contains a list of references.
- Section 13 - Glossary

2. Wave Energy and the Rationale for this Project

The power of waves is truly awesome. Mariners and others who deal with the forces of the sea have learned to appreciate the potential destructive and life-taking powers of the waves. Beachgoers are enthralled by the sight of the waves breaking and expending their energy on the shoreline. In order to understand the principles by which wave energy conversion devices work and to estimate the power of waves, it is necessary to understand the fundamentals of wave motion. It is not the purpose of this report to provide that understanding. There are many good books and websites by which that understanding can be obtained.

Three characteristics of waves important to the generation and dispatch of electricity from wave energy conversion devices are: 1) power density, 2) intermittency and 3) predictability. As shown in Table 1 below, wave energy has the highest power density of the four renewable resources shown. While the ocean is never totally calm, wave power is more continuous than the winds that generate it. The average power during the winter may be 6 times that obtained during the summer and power values may vary by a factor of a hundred with the random occurrences of storms. Therefore, the power of waves is highly variable. The predictability of wave energy is on the order of a few days. The waves resulting, for example, from storms that occur off the coast of Japan, will take that long to reach the northwest coast of the United States.

Table 1. Renewable Resource Attributes Important to Electricity Generation and Dispatch

	Solar PV	Wind	Wave	Tidal Flow
Dev Status	Early Com'l	Commercial	Pre Com'l	Pre Com'l
Energy Source	Sun	Sun	Sun-Wind	Gravity
Power Density	1 kW/m ² - at peak solar insolation	1 kW/m ² - at 12m/s (GE 1.5MW machine)	25 kW/m ² - at San Francisco avg annual power flux	5 kW/m ² - at 3m/s water flow rating
Hourly Variability	Daily cycles - clouds	When it blows	24-7 and highly variable	Diurnal cycles
Predictability	Poor	Hours	Days	Centuries

The potential benefit of being able to include wave energy renewable resources in our mix of generation options for the future is significant. On a national level, developing domestic renewable energy technologies increases our energy self-sufficiency. This enhances our security and provides a hedge against the geo-political volatility of oil producing nations while also supporting the creation of local jobs and developing a strong economy. On a global level, renewable energy technologies can enable developing countries to electrify their populations to a foundation level of 1,000 kWh per capita per year, thus improving the global standard of living while mitigating the deleterious impact of fossil fuel emissions on the planet. We believe that ocean energy has substantial promise and is a large and as yet untapped energy resource that is too important to overlook

3. Project Approach

The engineering approach followed to accomplish the Offshore Wave Energy Feasibility Demonstration Program – Phase I Project Definition Study is illustrated in the flow diagram shown in Figure 1.

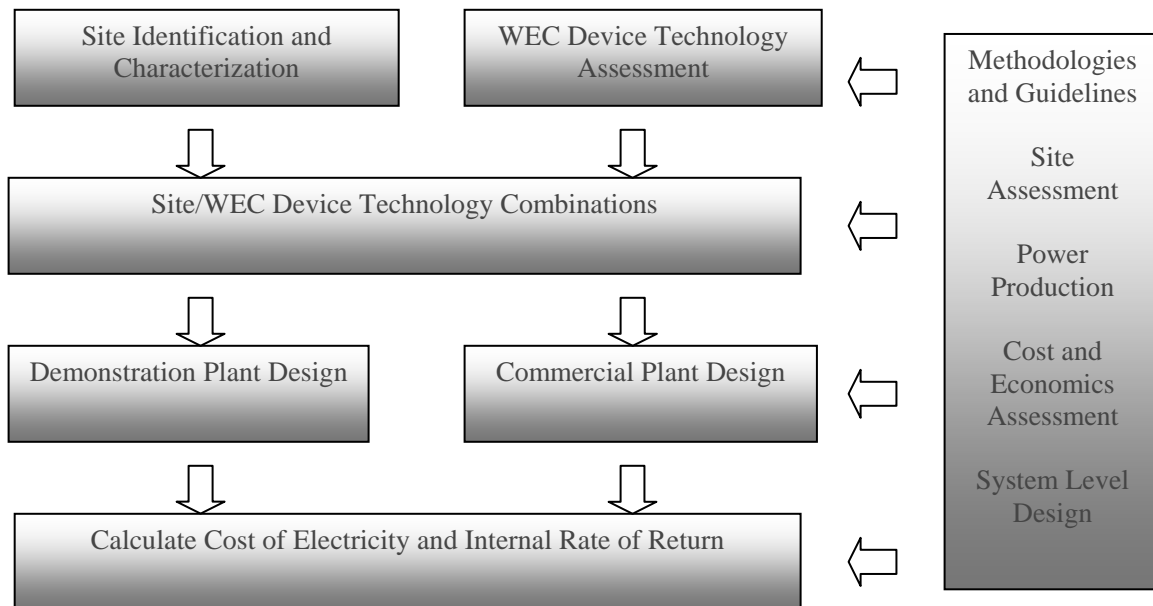

Figure 1: Project Definition Study – Technical Approach Flow Chart

In contrast to this technical approach for looking at a wave power system and its costs, a business perspective asks the operative question: “Does it make money?”

For a utility generator, capital and O&M cost are annualized and the cost of electricity (COE) is calculated by dividing the annualized cost by the annual energy produced.

A non utility generator views the system as a stream of cash flows with an end product of a return on investment (ROI). A project developer would have to convince potential investors that a wave energy plant would provide a sufficient internal rate of return (IRR), in order to justify project financing.

The Project Team addressed the performance of offshore wave energy power plants from both technical and business viewpoints and the results are presented in this report.

4. Methodology Development

When the Project Team started this project, no standards existed for resource assessment, plant design, performance prediction, or cost estimation for offshore wave energy systems. Therefore, the Project Team developed three guidelines in order to enable the completion of this Project Definition Study:

- A design guideline to develop realistic reference designs and to form a solid foundation for further detailed design efforts (Reference 5).
- A performance estimating guideline to predict the annual electrical power production of the plants (Reference 1).
- A cost estimating and economic assessment guideline to enable the calculation of the COE and IRR and to compare the cost and economics of offshore wave power plants with other renewable energy options (Reference 2).

In addition, no standards exist for the construction, operation and maintenance of offshore wave power plants. The offshore oil and gas industry, which has considerable experience in this field, has developed many standards for fixed and floating offshore platforms, and these were applied in this project.

Grid interconnection standards and common practices were adopted from the electric power industry. For this study, the Project Team applied IEEE 1547 as the most relevant standard to interconnect the offshore wave power plant with the electric grid

5. Site Identification and Characterization

An ideal site to deploy, operate and maintain an offshore wave energy power plant must have many attributes. First and foremost is the native energy and energy spectra potential.¹ The U.S. regional wave regimes and the total annual incident wave energy for each of these regimes is shown in Figure 2. The total U.S. available incident wave energy flux is about 2,300 TWh/yr. The DOE Energy Information Energy (EIA) estimates 2003 hydroelectric generation to be about 270 TWh which is a little more than a tenth of the yearly offshore wave energy flux into the U.S. Therefore, wave energy is a significant resource.

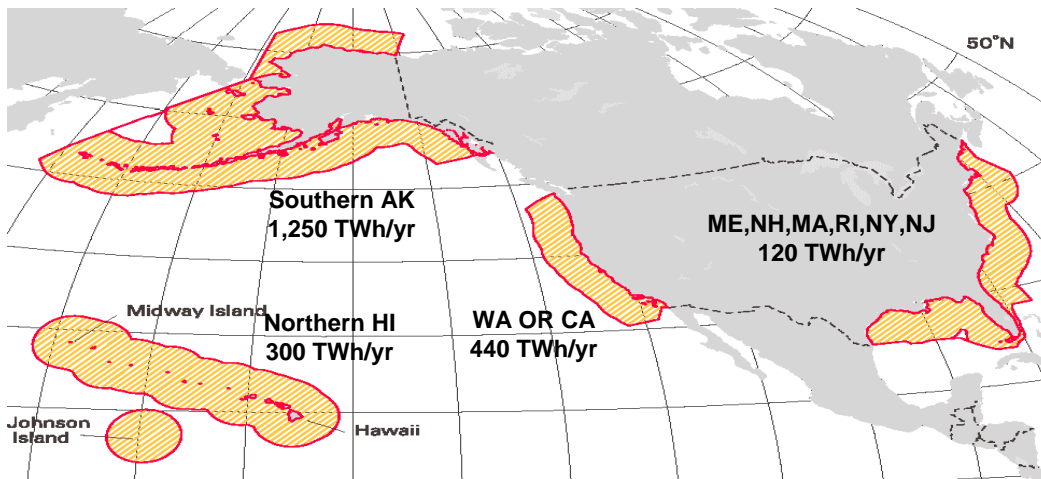

Figure 2: U.S. Wave Energy Resources

Site attributes characterized by the Project Team included offshore bathymetry² and seafloor surface geology, robustness of the coastal utility grid, regional maritime infrastructure for both fabrication and maintenance, conflicts with competing uses of sea space and existence of other unique characteristics that might minimize project development costs (e.g., existing ocean outfall easements for routing power cable and shore crossing). EPRI Technical Reports describe the results of site identification and characterization for the four states of Hawaii, Washington, Oregon and Maine (References 3 through 6). The sites chosen for five point design studies performed in this project are:

State	County	Harbor	Grid Interconnection
CA	San Francisco	San Francisco	Ocean Beach Water Treatment Plant
HI	Oahu	Honolulu	Makai Pier distribution, Waimanalo Beach
ME	Cumberland	Portland	Old Orchard Beach Substation
MA	Boston	Boston	Wellfleet distribution line
OR	Douglas County	Coos Bay	Gardiner Substation

Key site parameters are described in section 7

¹ Energy as function of wave height and wave period or frequency

² Bathymetry is the depth of the seafloor below mean water height (i.e., the inverse of a topographic map)

6. Wave Energy Conversion Device Assessment

The Project Team requested information from all known Wave Energy Conversion (WEC) Device manufacturers in January 2004. The information received was assessed to determine which devices to use for the purpose of the point designs for the pilot demonstration and commercial power plants at each of the five (5) sites described in the previous section.

Twelve (12) companies responded to our request for information. An initial screening used two key issues 1) technology readiness (is the device likely to be ready for demonstration in the 2006 time period?) and 2) survivability (has the device manufacturer provided sufficient technical information to prove the survivability in storm conditions?).

Table 2: WEC Device Manufacturers that Responded to Request for Information

Rating ¹	Company	Device Length (m)	Device Width (m)	Device Wt (tons)	Avg Power (kW) ²	Device Weight (tons)	Principle of Operation	Power Train
1	Ocean Power Delivery	120	4.6	380	153	380	Floating Attenuator	Hydraulic
2	Energetech	25	35	450	259	450	Bottom mounted Terminator – OWC	Air Turbine
2	Wave Dragon	150	260	22,000	1369	22,000	Floating overtopping Ramp	Low Head Hydro
2	Wave Swing	9.5	9.5	NA	351	NA	Bottom mounted Point Absorber	Linear Generator
3	WaveBob	15	15	440	131	440	Floating Point Absorber	Hydraulic
3	Aqua Energy	6	6	22	17	22	floating Point Absorber	Water Pump
3	OreCON	32	32	1250	532	1250	floating OWC	Air/Hydraulic
3	Independent Natural Resources Inc	5.4	5.4	112	16	112	Bottom mounted Point Absorber	Water Pump

(1) Maturity rating

(2) Oregon reference station CDIP 0037 Coquille River with annual wave energy resource of 21.2 kW/m is the measurement station used to evaluate the performance for this table

The eight (8) devices which passed the initial screening criteria are shown in the above table. These 8 devices were then assessed with the objective of determining any critical issues and recommending RD&D needed to achieve technological readiness for an at sea demonstration. That assessment is contained in Technical Report 004 (Ref 7). As a result of this assessment, the eight devices were grouped into one of three levels of development categories:

- Level 1 – Development complete and full-scale testing in the ocean underway
- Level 2 – Development near complete. Only deployment, recovery and mooring issues are yet to be validated. There are funded plans for full-scale at sea testing
- Level 3 – Most critical R&D issues are resolved. Additional laboratory and sub-scale testing, simulations and systems integration work is needed prior to finalization of the full-scale design. There are no funded plans for full-scale at sea testing.

At the time of our analysis (March 2004), only one WEC device manufacturer had attained a level 1 technology readiness status, namely, Ocean Power Delivery with its Pelamis device. At this time (January 2005), there are an additional four WEC device manufacturers that are close to reaching that status, namely: TeamWorks of the Netherlands with its WaveSwing, Energetechs of Australia with its oscillating water column, WaveDragon of Denmark with its overtopping device and Ocean Power Technology of the U.S. with a floating buoy.

7. Power Plant Design, Performance, Cost and Economic Assessment

Offshore Wave Power Plant Design, Performance and Cost Technical Reports have been published for sites in Hawaii, Oregon, San Francisco, Massachusetts and Maine (References 9 through 13). Designs have been developed for both demonstration-scale and commercial-scale power plants. All plants are based on the Ocean Power Delivery (OPD) Pelamis WEC device. In addition, a second design was performed for the San Francisco California site with an Energetech oscillating water column (OWC) device.

Site Parameters

Key parameters of the five sites are provided in the following table. Two designs, one with the Pelamis device and the second with the Energetech device, was performed for the San Francisco site.

Table 3: Key Site Parameters

	Hawaii Pelamis	Oregon Pelamis	California Pelamis Demo / Com'l ⁽¹⁾	California Energetech Demo / Com'l ⁽¹⁾	Mass Pelamis	Maine Pelamis
Distance from shore to plant	2 km	3.5 km	13 / 28.5 km	14 / 22.5 km	9.1 km	9.2 km
Water depth at site	50-60 m	50-60 m	30 / 50-60 m	15 / 40 m	50-60 m	50-60 m
Average Annual Wave Energy Power Flux at site	15.2 kW/m CDIP 034	21.2 kW/m CDIP 0037	11.2 kW/m CDIP0062 / 20 kW/m NDBC 44026	11.2 kW/m CDIP0062 / 20 kW/m NDBC 44026	13.8 kW/M NDBC 44018	4.9 kW/m NDBC 44007
Power Cable Landing	Makai Pier	Int'l Paper Outflow Pipe	Wastewater Outflow Pipe	Wastewater Outflow Pipe	Directional Drilling	Directional Drilling
Grid Inter Connect (I/C) Point	Waimanalo Beach S/S	Gardiner S/S	Ocean Beach Water Treatment Plant	Ocean Beach Water Treatment Plant	Wellfleet distribution line	Old Orchard Beach S/S
I/C Distance from shore	0.5 km	4 km ⁽²⁾	0.5 km	0.5 km	0.5 km	0.5 km
Ocean floor sediments	Bedrock & Limestone	Sand and Mud	Soft Sediments	Soft Sediments	Sand	Gravel, Rock, Sand
Distance from harbor	40 km	25 km	31 / 40 km	26 / 42 km	72 km	30 km

1. The demonstration plant is sited within the exclusionary zone in 35 meter deep water whereas the commercial plant is sited outside the zone in 60 meter deep water
2. The Gardiner substation is located adjacent to the International Paper Plant and the shore end of the effluent pipe

WEC Device - Pelamis

The Pelamis WEC device consists of four cylindrical steel sections which are connected by three hydraulic power conversion modules (PCM). Total length of the device is 120m and device diameter is 4.6m. Figure 3 shows the device being tested off the Scottish coast.

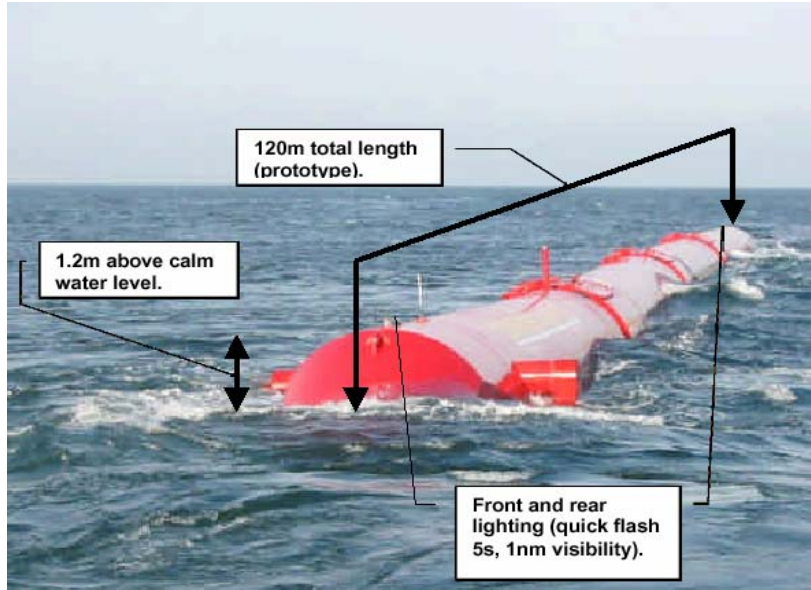

Figure 3: Pelamis pre-production prototype undergoing sea-trials

Mooring - Pelamis

The prototype Pelamis mooring system (Figure 4) is a catenary type mooring using a combination of steel wire rope, chain, dead weights and embedment anchors.

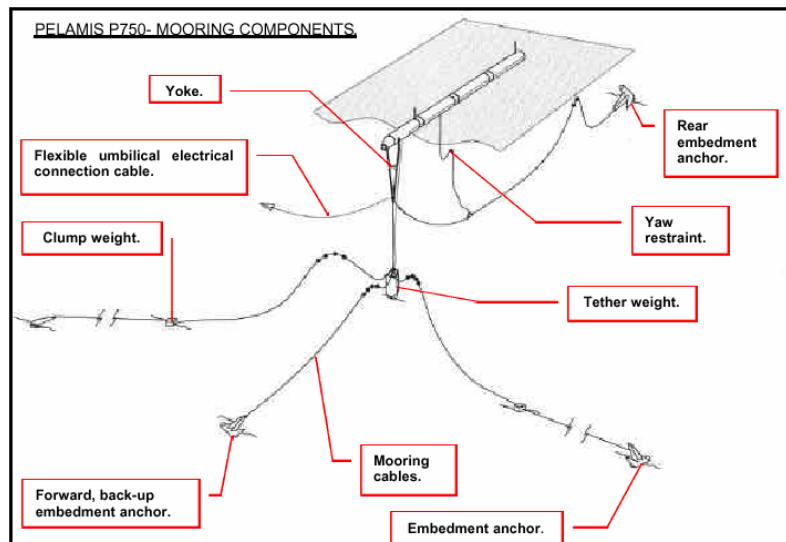

Figure 4: Mooring Arrangement of Prototype Pelamis Design

WEC Device and Mooring – Energetech

The Energetech device, using the oscillating water column (OWEC) principle, is illustrated with its major components in Figure 5. The device is standing on 4 support legs. The length of these legs depends on the water depth at the deployment site. Mooring chains hold the structure in place and are attached to steel piles on the other side, providing good anchoring capabilities. At the time this report is being written, Energetech has completed the construction of the prototype device, which will be deployed with operation commencing in early 2005 at Port Kembla in Australia.

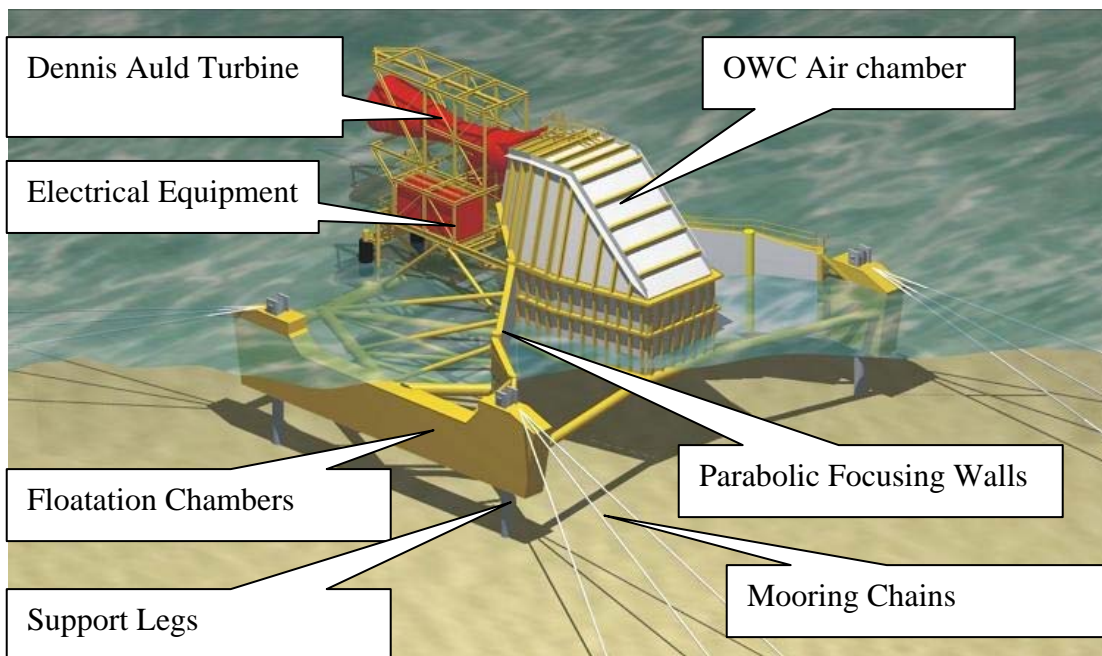

Figure 5: Prototype Energetech WEC Device and Mooring Design

Electrical Interconnection and Performance of Demonstration Plant – Oregon Example

The drawing below (Figure 6) shows the electrical interconnection of the demonstration plant for the Oregon site. A single floating Pelamis device is moored in a water depth of 50m – 60m. An umbilical riser cable connects the Pelamis to a junction box on the ocean floor. From this junction box, a double-armored 3-phase cable is buried into soft sediments along a 3-km route leading to the outfall of the effluent pipe, which is 1 km offshore. The cable is then routed through the 5 km effluent pipe to the International Paper Facility, which is about 4 km inland. An additional cable section connects to the Gardiner substation located next to the property of the International Paper facility.

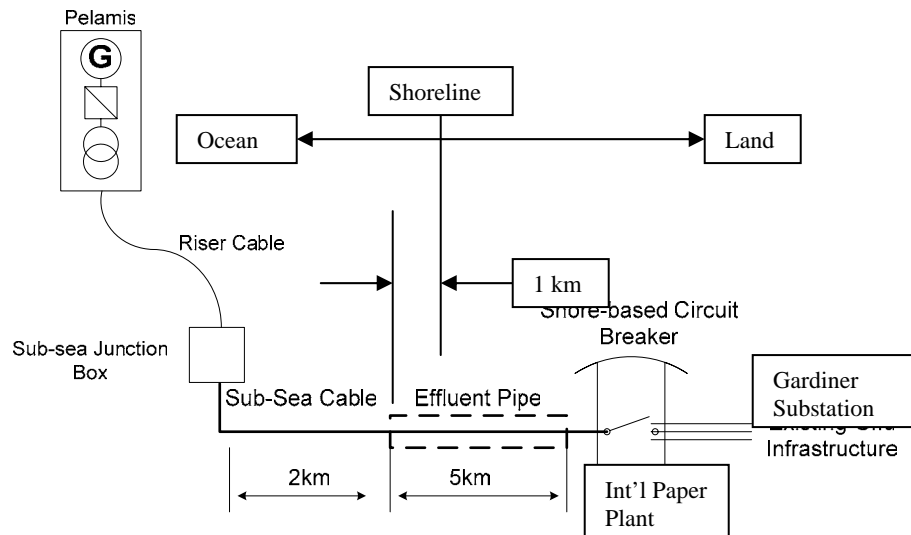

Figure 6: Electrical Interconnection of a Single Pelamis Unit Plant – Oregon Example

The estimated performance of the single device demonstration plant at each of the five sites is shown in the following table.

Table 4: Estimated Performance of Pilot Demonstration Plants

	Hawaii Pelamis	Oregon Pelamis	California Pelamis	California Energetech	Mass Pelamis	Maine Pelamis
Rated Capacity (kW)	750	750	750	1,000 kW	750	750
Annual Energy Absorbed (Mwh/yr)	1,989	1,472	1,229	1,643	1,268	426
Annual Energy Produced (MWh/yr)	1,663	1,001	835	1,264	964	290
Average Electrical Power at Busbar (kW)	180	114	95	144	98	33
Number of Homes Powered by Plant	180	114	95	144	98	33

Availability = assumes 85% for demonstration plant
 Power Conversion Efficiency = assumes 80% for Pelamis demonstration plant
 Power conversion efficiency and directionality factor each 90% for Energetechs
 Annual average power per home is 1 kW from the EIA

Electrical Interconnection and Performance of Commercial Plant – Oregon Example

As shown in Figure 7, the commercial system uses a total of 4 clusters, each one containing 45 Pelamis units (i.e., 180 total Pelamis WEC devices), connected to sub-sea cables. Each cluster consists of 3 rows with 15 devices per row. The other state designs are organized in a similar manner with 4 clusters. The number of devices per cluster varies such that each plant produces an annual energy output of 300,000 MWh/yr. The 4 sub-sea cables connect

the 4 clusters to shore as shown in Figure 6. The electrical interconnection of the devices is accomplished with flexible jumper cables, connecting the units in mid-water. The introduction of 4 independent sub-sea cables and the interconnection on the surface will provide some redundancy in the wave farm arrangement.

The 4 clusters are each 2.25 km long and 1.8 km wide, covering an ocean stretch of roughly 9 km. The 4 arrays and their safety area occupy roughly 16 square kilometers. Further device stacking of up to 4 rows might be possible reducing the array length, but is not considered in this design since subsequent rows of devices will likely see a diminished wave energy resource and therefore yield a lower output. Such effects and their impacts on performance are not well understood at present.

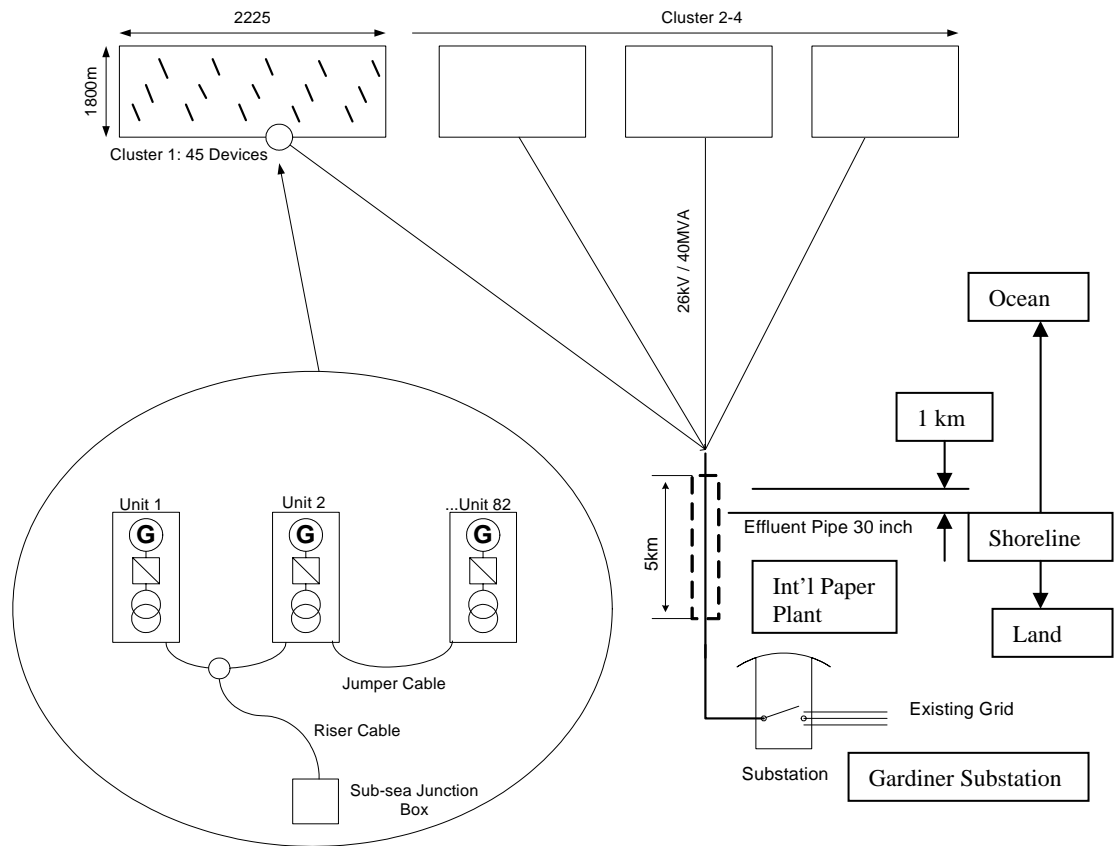

Figure 7: Arrangement and Electrical Interconnection of Commercial-Scale Plant

Individual units are arranged in wave farms to meet specific energy demands in a particular site as illustrated in Figure 8.



Figure 8: A Typical Pelamis Wave Farm

The estimated performance of the commercial-scale plant at each of the five sites is shown in the following table. The device rated capacity has been derated from 750 kW in the demonstration plant to 500 kW for the commercial plant. The performance assessment of the demonstration plants shows that the PCMs are overrated and reducing the rated power to 500kW per device would yield a significant cost reduction and only a relatively small decrease in annual output (attributed to the fact that the U.S. sites have a lower energy level than UK sites for which the device was originally developed).

Table 5: Estimated Performance of Commercial Plants

	Hawaii Pelamis	Oregon Pelamis	California Pelamis	California Energetech	Mass Pelamis	Maine Pelamis
Rated Capacity (kW)	500	500	500	1,000	500	500
Annual Energy Absorbed (Mwh/yr)	1,989	1,997	1,683	2,714	1,738	584
Annual Energy Produced (MWh/yr)	1,663	1,669	1,407	1,973	1,453	488
Average Electrical Power at Busbar (kW)	191	191	161	225	166	56
Number of Homes Powered by Plant	191	191	161	225	166	56

Availability = assumes 95% for demonstration plant

Power conversion efficiency = assumes 88% for Pelamis

Power conversion efficiency = 90% and Directionality factor = 85% for Energetechs

Annual average power per home = 1 kW per EIA data

For each state, point designs for both a single unit demonstration and a commercial size wave power plant were used to come up with cost and performance numbers. Performance numbers were established using local wave data obtained from measurement buoys and

performance data supplied by the manufacturer. Costing models were established by creating a detailed breakdown of the various cost centers, outlines of installation and operation procedures and cross checking them with a variety of sources, including local operators, the design team, local manufacturers and similar offshore projects in the Oil & Gas and offshore wind industry.

Demonstration and Commercial Scale Plant Cost Estimates

Cost assessments were made for the demonstration plant was carried out using a rigorous assessment of each cost center. Installation activities were outlined in detail and hourly breakdowns of offshore operational activity were created to properly understand the processes and associated cost implications. Wherever possible, manufacturing estimates were obtained from local manufacturers. An uncertainty range was associated with each costing element and a Monte Carlo Simulation was run to determine the uncertainty of capital cost. Cost centers were validated by Ocean Power Delivery (the selected WEC device manufacturer) based on its production experience of their first full scale prototype machine, which was deployed in 2004. The cost estimate range, both before and after incentives (such as the 10% federal investment tax credit, the 25% Oregon investment tax credit (limit of \$10 million), the California 6% investment tax credit and the Massachusetts installation cost tax deductibility), is shown in the following table.

Table 6: Pilot Demonstration Plant Installed Capital Cost – Before and After Incentives

Installed Capital Cost (\$M) ⁽¹⁾	Hawaii Pelamis	Oregon Pelamis	Calif Pelamis	Calif Energetech	Mass Pelamis	Maine Pelamis
Before Incentives						
Lower to Upper Cost Estimate	3.6-5.5	3.7-5.7	4.4 – 7.3	3.9 – 7.2	4.4-6.9	4.8-7.7
After Incentives						
Lower to Upper Cost Estimate	3.3-5.0	2.5-3.8	3.7 – 6.1	3.3 – 6.0	3.9-6.0	4.4-6.9

Cost assessments for the commercial wave power plant were carried out using the same rigorous assessment processes of the demonstration plant costing. Instead of simply applying learning curves to the demonstration unit, a point design for the commercial plant was established and its cost estimated. For cost centers which lend themselves well to cost reduction, outlines were created of how such cost reduction will be achieved. Cost centers were validated by Ocean Power Delivery based on their production experience of their first full scale prototype machine which was deployed in 2004. Plant inspection, maintenance, and repair tasks and outlines were validated by local marine operators.

Table 7. Utility Generator Commercial Plant COE after Tax Incentives

Commercial Plant	Hawaii Pelami	Oregon Pelami	Calif Pelamis	Calif Energetech	Mass Pelami	Maine Pelamis
Number of Pelamis Units Needed for 300,000 MWh/yr	180	180	213	152	206	615
Total Plant Investment (\$M)	270	235	279	238	273	735
Annual O&M Cost (\$M)	11	11	13	11	12	33
10-Year Refit Cost (\$M)	24	23	23	15	26	74
COE (cents/kWh) nominal	12.4	11.6	13.4	11.1	13.4	39.1
COE (cents/kWh) real	10.4	9.7	11.2	9.2	11.1	32.2

The breakdown of the commercial plant COE for each of the major element areas is shown in the pie chart of Figure 9. A few significant findings observed from this chart are:

- Large impact of O&M cost (one of the main reasons for feasibility demonstration testing)
- The three critical cost centers which are 1) Absorber structure (steel cost), 2) Power Take Off and 3) Moorings
- The sub sea transmission and infrastructure cost, which were a high cost percentage cost center for the pilot-scale plant, tend to disappear or the commercial-scale plant.

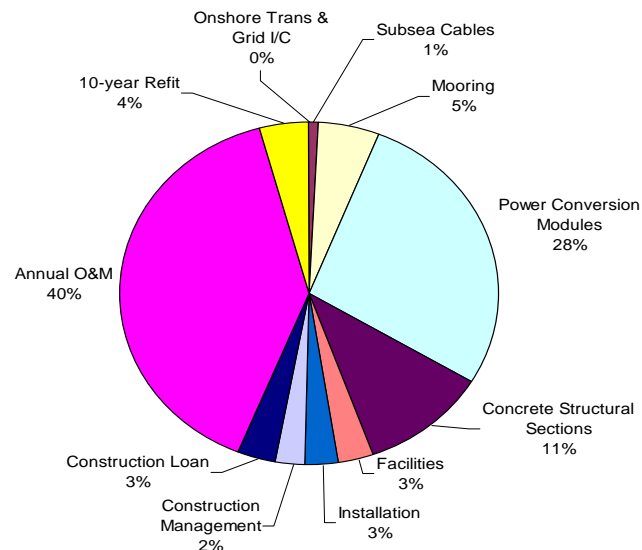

Figure 9: Commercial Plant COE Breakdown

Learning Curves, Plant Cost of Electricity and Comparison with Wind Technology

The costs and cost of electricity shown in the previous section are for the *first* commercial scale wave plant. It is an established fact that learning through production experience reduces costs – a phenomenon that follows a logarithmic relationship such that for every doubling of the cumulative production volume, there is a specific percentage drop in production costs. The specific percentage used in this study was 82%, which is consistent with documented experience in the wind energy, photovoltaic, shipbuilding, and offshore oil and gas industries.

The industry-documented wind energy learning curve is shown as the top line in Figure 8 (Reference 16). The cost of electricity is about 4 cents/kWh in 2004 U.S. dollars based on 40,000 MW of worldwide installed capacity and a good wind site. The lower and higher bound cost estimates of wave energy are also shown in Figure 8. The 82% learning curve is applied to the wave power plant installed cost but not to the operation and maintenance part of the cost of electricity (hence the reason that the three lines are not parallel).

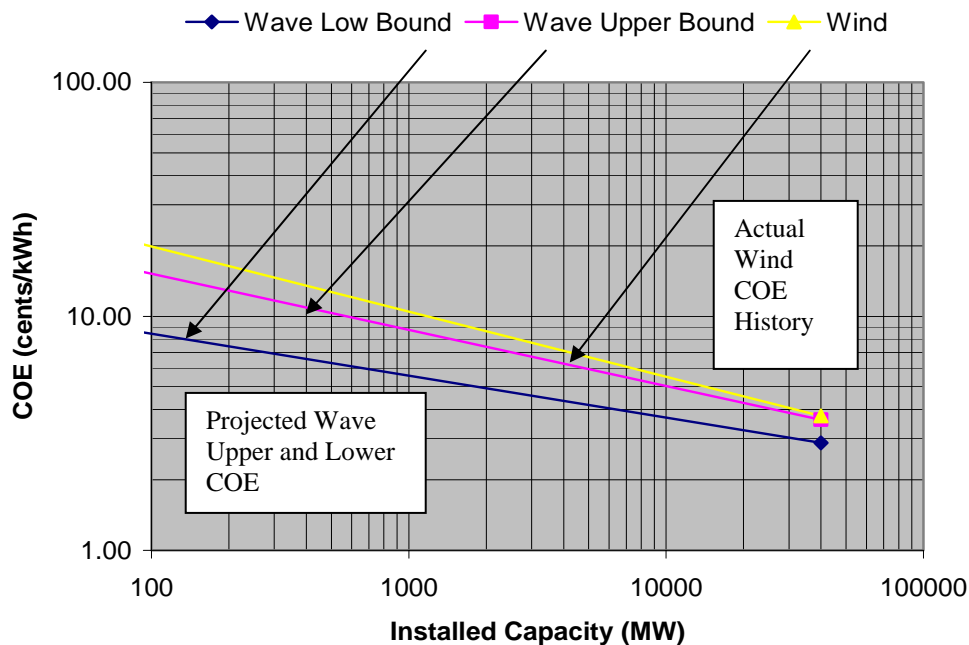

Figure 10: Levelized COE comparison to wind – Oregon Example

Figure 10 shows that the cost of wave-generated electricity is less than wind-generated electricity at any equal cumulative production volume under all cost estimating assumptions for the wave plant. The lower capital cost of a wave machine (compared to a wind machine) more than compensates for the higher O&M cost for the remotely located offshore wave machine. A challenge to the wave energy industry is to drive down O&M costs to offer even more economic favorability and to delay the crossover point shown at greater than 40,000 MW.

8. Environmental Issues

Like any electrical generating facility, a wave power plant will affect the environment in which it is installed and operates. There is no actual environmental effects data available at this time (the first full scale prototype machine deployed at sea and generating electricity into the electrical grid occurred in the summer of 2004). There are some studies in Europe that are beginning to examine the potential environmental impacts of wave power and to document demonstrations in a timely fashion (see Section E of the Wave Energy Thematic Network at <http://www.wave-energy.net>) Given the limited timeframe of this study, the Project Team considered the following six environmental issues which are reported in full in Reference 15:

- Withdrawal of wave energy
- Interactions with marine life and seabirds
- Atmospheric and oceanic emissions
- Visual appearance
- Conflicts with other uses of sea space
- Installation and decommissioning

Withdrawal of Wave Energy

Offshore wave power plants will not present an impervious barrier to waves traveling shoreward. Gaps between devices and less-than-100% absorption efficiency will allow considerable wave energy to pass through the plant. Given the potential sensitivity of the surfing community to this effect, the Project Team estimated the amount of wave energy that would be withdrawn by the commercial plant design at Waimanalo Beach, Oahu, Hawaii.

The commercial design used 180 Pelamis devices divided into 4 clusters of 45 units each with each cluster configured as three rows, with 15 Pelamis device per row. The total width of the wave power plant is 12 km and includes 600 meter navigation lanes between the clusters. The total reduction in wave height was found to be 12% immediately behind the plant.

Undiminished wave energy that passes to either side of the plant will spread into the lower-energy zone immediately behind the plant by diffraction. By the time the waves reach shoaling and breaking depths, their height will have been somewhat re-established by this process, at the expense of adjacent waves, thereby resulting in a broader region of lesser impact. The Pelamis, and other floating wave energy devices preferentially absorb energy from shorter-period waves, having less effect on the longer-period swell that produce the spectacular surfing waves on Oahu's north shore. Overall, then, we expect that the reduction in height of surfing waves would be in the range of 5-10%. Suitable before-and-after monitoring of the first commercial plant sites must be undertaken to accurately measure this effect. And, early dialogue with the surfing community is required in order to find a balanced and reasonable solution for the coexistence of wave power production and surfing.

Interactions with Marine Life and Seabirds

Low-freeboard devices may provide hauling-out space for seals and sea lions, while high-freeboard devices may provide colonization space for seabirds. As marine pinnipeds and seabird populations become adapted to this artificial space, care must be taken in the decommissioning schedule to mitigate potential impacts to these populations. There is an expected level of disturbance to the seabed and benthos during installation and maintenance, but these impacts have not been defined as yet.

Atmospheric and Oceanic Emissions

For devices using close-circuit hydraulics, working fluid spills or leakage may be a concern. For devices with equipment mountings on submerged hull surfaces, underwater noise is a concern. For devices with air turbines, atmospheric noise is a concern. These concerns can be mitigated to various extents through system design features. Appropriate environmental monitoring of these effects also must be performed.

Visual Appearance

Offshore wave power plants are not likely to be visually intrusive on the seascape as viewed from the shore, even from elevated shoreline positions, due to the presence of natural sea haze, even on sunny days. This is particularly true of low-freeboard devices, which are intermittently obscured by wave crests.

Because of the high level of fishing activity in offshore shelf waters, floating devices will have to be appropriately marked as a navigation hazard. In addition to lights, sound signals, and radar reflectors, highly contrasting day-markers will be required. Day-markers that meet the Coast Guard requirement of being visible within one nautical mile (1.8 km) at sea are expected to have negligible visual impact when viewed from shore.

Conflicts with Other Uses of Sea Space

The potential for conflict with other users of sea space must be addressed early in the siting of offshore wave power plants. Potential conflicts may exist with marine protected areas, shipping, fishing, scientific research areas, military warning areas, telecommunication cable routes and dredge spoil disposal sites. Most of these may be avoided with appropriate research during site selection and early dialogue with groups that might be affected.

Installation and Decommissioning

Wave power plant installation issues that must be addressed include routing and shore crossing of submarine power cables. Cable installation activities are likely to occur during the calm summer months, and on the West Coast, this would avoid the peak grey whale migration months of March – May and November – December. Decommissioning issues

include the disposition of fixed structures on the sea floor, the gradual removal of floating platforms in stages (e.g., if there is evidence of use as haul-out space by seals and sea lions or colonization by seabirds).

Environmental Benefits

Wave energy can have a number of other benefits in both the environmental and social areas. For example, in remote coastal areas, including small islands, it can help reduce the reliance on auxiliary (diesel) power stations. In addition to the resultant reduction of the emission of combustion gases to the atmosphere, the transport of the fuel to the site, often by water, is largely eliminated, which in turn reduces the environmental risks associated with this means of transportation. Currently, many remote coastal areas receive their electricity via overhead transmission lines, which are often perceived to have adverse visual impacts. Again, such impacts would be reduced by having separate wave power installations serving individual coastal communities.

The First U.S. Offshore Wave Energy Device Environmental Assessment (EA)

The first U.S. Wave Energy Project Environmental Assessment (EA) evaluated the potential environmental impacts of a proposed phased installation and operational testing over a two year period of up to six Wave Energy Conversion (WEC) buoys off North Beach at Marine Corps Base Hawaii (MCBH) Kaneohe Bay (the Proposed Action).

Ten potentially affected resources were identified for this project and none were found to be significantly impacted by the proposed installation and operational testing of the WEC buoy and ancillary equipment. These resources were: shoreline physiography, oceanographic conditions, marine and terrestrial biological resources, land and marine resource use compatibility, cultural resources, infrastructure, recreation, public safety, and visual resources

Based on information gathered during the preparation of the EA, the Navy found that the proposed installation and operational testing of up to six WEC buoys at MCBH Kaneohe Bay Oahu Hawaii will not significantly impact human health or the environment and that there will be no cumulative effects from the proposed project

Conclusions

We conclude that, given proper care in site planning and early dialogue with local stakeholders, offshore wave power promises to be one of the most environmentally benign electrical generation technologies. We recommend that early demonstration and commercial offshore wave power plants include rigorous monitoring of the environmental effects of the plant and similarly rigorous monitoring of a nearby undeveloped site in its natural state (before and after controlled impact studies).

9. Permitting Issues

The issues involved with permitting an offshore wave energy plant are reported in Ref 16. Even though wave energy technologists may assume that there are no known environment concerns, the novelty of the technology at the federal and state level will likely trigger conservative evaluations and extensive approval processes. Permitting a wave power plant presents a significant barrier to the development of wave energy technology and to commercial use of the technology. The primary reasons are:

- There is a wide variety of regulations and agencies involved with no clear jurisdictional responsibilities, therefore each state and project is unique.
- No specific “fast-track” regulations have been developed for short-term marine renewable demonstration projects.

The primary Federal agencies with ocean jurisdiction include:

- Federal Energy Regulatory Commission (FERC – an independent agency)
- U.S. Army Corps of Engineers (U.S. Department of Defense)
- National Oceanic and Atmospheric Administration (U.S. Department of Commerce) oversees conservation and management of coastal and marine resources.
- Minerals Management Service (U.S. Department of Interior) oversees the management of offshore oil and gas and sand and gravel resources in the ocean.

Other federal agencies that are likely to be involved include the U.S. Coast Guard, the National Marine Fisheries Service, the U.S. Environmental Protection Agency, and the U.S. Fish and Wildlife Service. Various state and local agencies also participate in the permitting process. Reference 16 overviews the FERC licensing process as well as the status of the three U.S. offshore wave power projects that have completed or are in the licensing process:

- Ocean Power Technologies (OPT) – Kaneohe Bay, Marine Corps Base, HI
- AquaEnergy – Makah Bay, WA
- Energetech – Point Judith, RI

The OPT project is permitted, but is not a typical demonstration project. The Office of Naval Research coordinated the permitting process with the US Marine Corps, the US Army Corp of Engineers, and the State of Hawaii without FERC involvement. In the AquaEnergy project, and through the agency scoping process and legal interpretations, FERC became the agency with jurisdiction for licensing the project. This was the first time that FERC determined they have jurisdictional authority over a wave energy project. An Interagency Scoping Document was prepared and issued by the AquaEnergy in February 2004 and the preparation of an Environmental Assessment is underway. Lastly, the Energetech project has initiated the FERC ALP that will also involve a permit from the Rhode Island Coastal Resource Management Council.

10. Conclusions

The wave energy potential off the coast of the U.S. is significant. Harnessing just 24% of the available wave energy resource base (2,300 TWh/yr) at 50% conversion efficiency would generate as much electricity as all conventional hydropower now installed in the United States (270 TWh/yr)

Offshore wave energy technology is now ready for pilot scale demonstration testing in the US. The first time electricity was provided to the electrical grid from an offshore wave power plant occurred in early August 2004 by the full scale preproduction OPD Pelamis prototype in the UK. Although technologically ready for demonstration, many important questions about the application of offshore wave energy to electricity generation remain to be answered, such as:

- What type and size will yield optimal economics?
- Given a device type and rating, what capacity factor is optimal for a given site?
- Will the installed cost of wave energy conversion devices realize their potential of being much less expensive on a cost of electricity basis than solar or wind?
- Will the performance, cost and reliability projections be realized in practice once wave energy devices are deployed and operated?

Relative to commercial deployment of wave power technology, the following key conclusions were reached:

- Offshore wave energy will first be commercially introduced in Hawaii and Northern California due to the combination of an excellent wave climate and relatively high cost of electricity.
- Oregon has an excellent wave climate but a relatively low cost of electricity due to its hydro resources.
- Washington State has a very good wave climate, a low electricity cost. due to its hydroelectric resources, however, does not have a large coastal load nor transmission infrastructure.
- Massachusetts has a moderate wave climate in the winter, a poor wave climate in the summer, but, a relatively high cost of electricity and the existence of a REC market.
- Maine has a poor wave climate and appears to be partly shadowed by Nova Scotia. In addition, the bathymetry off the coast of Maine is very shallow.

We believe that this study makes a compelling case for investing in offshore wave energy technology research, development and demonstration.

11. Recommendations

The Project Team, on the basis of the results of this study, recommends:

1. Now that the project definition study phase of the Offshore Wave Energy Feasibility Demonstration Project is complete, proceed to the next steps of assessing local public support, local infrastructure interest (marine engineering companies and fabricators), analyzing site-specific environmental effects and developing an implantation plan for a detailed design, permitting, and acquiring construction financing.
2. If this first recommendation cannot be implemented at this time (due to lack of funding or other reason), we recommend that the momentum built up in Phase 1 be sustained in order to bridge the gap until Phase II can start by funding what we will call Phase 1.5 with the following tasks:
 - Tracking potential funding sources
 - Tracking wave energy test and evaluation projects overseas (primarily in the UK, Portugal and Australia) and in Hawaii
 - Tracking status and efforts of the permitting process for new wave projects
 - Track and assess new wave energy devices
 - Establish a working group for the establishment of a permanent wave energy testing facility in the U.S.
 - Develop Communications Plan and Messaging Kit for State Champions
3. For Maine and Massachusetts, initiate a simulation of the propagation or the wave energy spectra from known wave measurement locations at high spatial and bathymetric resolution throughout the Gulf of Maine to identify 'hot spot' sites for offshore wave energy systems.
4. Encourage wave energy technology R&D at universities to include technology cost reduction, improvement in efficiency and reliability, identification of sites, interconnection with the utility grid and study of impacts of the technology on marine life and the shoreline.

In order to accelerate the growth and development of an ocean energy industry in the United States and to address and answer the many techno-economic challenges listed in Section 10, a technology roadmap is need which can most effectively be accomplished through leadership at the national level.

The development of ocean energy technology and the deployment of this clean renewable energy technology would be greatly accelerated if the Federal Government were supporting the development. Appropriate roles for the Federal Government in ocean energy development could include some, or all, of the following:

- Providing leadership for the development of an ocean energy RD&D program to fill known R&D gaps identified in this report, and to accelerate technology development and prototype system deployment
- Operating a national offshore wave test center to test the performance and reliability of prototype ocean energy systems under real conditions
- Development of design and testing standards for ocean energy devices
- Joining the International Energy Agency Ocean Energy Systems Implementing Agreement to collaborate RD&D activities, and appropriate ocean energy policies with other governments and organizations
- Leading activities to streamline the process for licensing, leasing, and permitting renewable energy facilities in U.S. waters
- Studying provision of production tax credits, renewable energy credits, and other incentives to spur private investment in ocean energy technologies and projects, and implementing appropriate incentives to accelerate ocean energy deployment
- Ensuring that the public receives a fair return from the use of ocean energy resources
- Ensuring that development rights are allocated through a transparent process that takes into account state, local, and public concerns.

12. References

EPRI Wave Power (WP) Reports are available on our website www.epri.com

- 1) WP-001-US Guidelines of Preliminary Estimation of Power Production by Offshore Wave Energy Conversion Devices
- 2) WP-002-US Rev 4 Cost of Electricity (COE) Assessment Methodology for Offshore Wave Energy Devices
- 3) WP-003-HI Results of Survey and Assessment of Potential Offshore Wave Energy Site Locations in Hawaii
- 4) WP-003-WA Results of Survey and Assessment of Potential Offshore Wave Energy Site Locations in Washington
- 5) WP-003-OR Results of Survey and Assessment of Potential Offshore Wave Energy Site Locations in Oregon
- 6) WP-003-ME Results of Survey and Assessment of Potential Offshore Wave Energy Site Locations in Maine
- 7) WP-004-US Rev 1 Assessment of Offshore Wave Energy Conversion Devices
- 8) WP-005-US Methodology, Guidelines and Assumptions for the Conceptual Design of Offshore Wave Energy Power Plants (Farms)
- 9) WP-006-HI System Level Design, Preliminary Performance and Cost Estimate – Hawaii
- 10) WP-006-OR System Level Design, Preliminary Performance and Cost Estimate – Oregon
- 11) WP-006-ME System Level Design, Preliminary Performance and Cost Estimate – Maine
- 12) WP-006-MA System Level Design, Preliminary Performance and Cost Estimate – Massachusetts
- 13) WP-006-SFa System Level Design, Preliminary Performance and Cost Estimate – San Francisco, California Pelamis Offshore Wave Power Plant
- 14) WP-006-SFb System Level Design, Preliminary Performance and Cost Estimate – San Francisco Energetech Offshore Wave Power Plant
- 15) WP-007-US Identification of Environmental Issues
- 16) WP-008-US Identification of Permitting Issues
- 17) “Wind Energy Costs” NWCC Wind Energy Series, Jan 1997, No 11

13. Glossary

What is ocean energy?

“*Ocean energy*” is a term used to describe all forms of renewable energy derived from the sea including wave energy, tidal energy, ocean current energy, salinity gradient energy and ocean thermal gradient energy. Wave energy is one of the forms of ocean energy:

- **Wave energy** occurs due to movements of water near the surface of the sea. Waves are formed by winds blowing over the water surface, which make the water particles adopt circular motions. This motion carries kinetic energy, the amount of which is determined by the speed and duration of the wind, the length of sea it blows over, the water depth, sea bed conditions and also interactions with the tides. Waves occur only in the volume of water closest to the water surface, whereas in tides, the entire water body moves, from the surface to the seabed; and

How can wave energy be harnessed?

A wide variety of concepts have been proposed for the extraction and conversion of wave energy to electricity. Some of these are introduced below: The problem of wave energy extraction is complex and many designs of device have been proposed. It is helpful to introduce these in terms of their physical arrangements and energy conversion mechanisms.

- **Placement** – Devices may convert wave power at the shoreline, near to the shore or offshore. The distinction between near-shore and offshore is often related to design requirements for water depth (this generally increasing with distance from shore), the energy content of waves (this being greater offshore), and access for deployment, retrieval, operation and maintenance.
- **Fixing** – Near-shore and offshore devices may be either bottom-mounted or floating, the former being fixed to the seabed by a static member and the latter moored to hold on station.
- **Reaction** – Wave energy devices need a system of reacting forces in order to extract energy and this is one of the biggest design challenges. To create such a system, two or more bodies need to move relative to each other, while at least one body interacts with the waves. There are numerous approaches. One approach is to allow one body to move freely with the waves, while another is held static (as in the case of a floating buoy reacting against the seabed). Alternatively, all of the bodies may be dynamic.
- **End stop** – Within the reaction system, a common requirement is to avoid situations where the relative motion is so large that destructively high forces occur between the bodies, (e.g. a hydraulic piston being forced beyond the end of its stroke).

Wave energy devices can be classified by means of their reaction system, but it is often more instructive to discuss how they interact with the wave field. In this context, each moving body may be labeled as either a displacer or reactor.

- **Displacer** – This is the body moved by the waves. It might be a buoyant vessel, or, as in the case of Oscillating Water Column (OWC) devices, a mass of water. If buoyant, the displacer may pierce the surface of the waves or be submerged.
- **Reactor** – This is the body that provides reaction to the displacer. As suggested above, it could be a body fixed to the seabed, or the seabed itself. It could also be another structure or mass that is not fixed, but moves in such a way that reaction forces are created (e.g. by moving by a different amount or at different times). A degree of control over the forces acting on each body and/or acting between the bodies (particularly stiffness and damping characteristics) are often required to optimize the amount of energy captured.

In some designs, the reactor is actually inside the displacer, while in others it is an external body. Internal reactors are not subject to wave forces, but external ones may experience loads that cause them to move in ways similar to a displacer. This can be extended to the view that some devices do not have dedicated reactors at all, but rather a system of displacers whose relative motion creates a reaction system.

The generality of the above might suggest there are many ways in which a wave energy device can be configured and indeed this is the case. Some of the most well-known device concepts are introduced below.

- **Oscillating Water Column (OWC)** – This comprises a partly submerged structure (‘collector’) which is open to the sea below the water surface so that it contains a column of water. Air is trapped above the surface of the water column. As waves enter and exit the collector, the water column moves up and down and acts like a piston on the air, pushing it back and forth. The air is channeled towards a turbine and forces it to turn. The turbine is coupled to a generator to produce electricity.
- **Overtopping** – This consists of a structure over which the waves topple, a reservoir to collect the water and hydro turbines installed at the bottom of the reservoir. The head of collected water turns the turbines as it flows back out to sea and the turbines are coupled to generators to produce electricity.
- **Point absorber** – This is a floating structure that absorbs energy in all directions by virtue of its movements at or near the water surface. It may be designed so as to resonate – that is, move with larger amplitudes than the waves themselves. This feature is useful to maximize the amount of power that is available for capture. The power take-off system may take a number of forms, depending on the configuration of displacers/reactors.
- **Terminator** – This is also a floating structure that moves at or near the water surface, but it absorbs energy in only a single direction. The device extends in the

direction normal to the predominant wave direction, so that as waves arrive, the device restrains them. Again, resonance may be employed and the power take-off system may take a variety of forms.

- **Attenuator** – This device is a long floating structure like the terminator, but is orientated parallel to the waves rather than normal to them. It rides the waves like a ship and movements of the device at its bow and along its length can be restrained so as to extract energy. A theoretical advantage of the attenuator over the terminator is that its area normal to the waves is small and therefore the forces it experiences are much lower.

There are many further different design concepts.

- One other device is the Wave Rotor, which is a form of turbine turned directly by the waves. It is coupled to a generator in order to generate electricity.
- Other devices use contained volumes of water, or exploit differences in water pressure. Flexible structures have also been suggested, whereby a structure that changes shape/volume is part of the power take-off system.

Common terms in wave energy

The energy content of waves is a function of wave height and wave period.

- **Sea state** – In real sea conditions, many wave heights and periods occur simultaneously and it is necessary to resort to a statistical description. Data for a particular site can be summarized on a scatter diagram, which is a record of the wave motions, showing the number of occurrences of particular combinations of H_s and T . Each combination of H_s and T is referred to as a sea state.

Wave energy generation devices

- **Efficiency** – This can be defined in several different ways. A simple view is to consider ‘resource-to-wire’ efficiency: the ratio of the energy a device actually captures to the energy that is available to be captured.
- **Availability** – The proportion of time a device is ready to generate, irrespective of whether the resource is suitable for generation.
- **Capacity factor** – The energy produced during a certain period divided by the energy that would have been produced had the device been running continually and at maximum output.